

# PowerGen

Maintenance-Free Electrical Power for the O&G Industry



# Company Overview

Decades of technology excellence led to a *Maintenance Free Generator*

- The emerging leader in Reliable Distributed Power for the 1-10 KW range, based on a Maintenance Free Generator
- Founded in 2009 as a subsidiary of Ricor, a global manufacturer of Stirling Cryocoolers
- Currently focused on the North American Oil & Gas and Transportation sector
- Advanced manufacturing facility in Ogden, Utah
- World-class Stirling experts



# “The longest-running heat engine in history”

According to [NASA](#), the free-piston Stirling has unparalleled reliability

- NASA testing on multiple engines over the past two decades demonstrated a world record for heat-engines by running a **free-piston Stirling engine in excess of 110,000 hours** (more than 12 years) of cumulative undisturbed operation.
- Qnergy’s engineers were active participants in the program. Qnergy continues to use the same design architecture.
- Like all Qnergy engines, the NASA test engines require no lubrication, maintenance, or repair.
- The NASA test engines continue to operate, forging even longer operating times.

IT KEEPS GOING AND GOING: STIRLING ENGINE TEST SETS LONG-DURATION RECORD AT NASA GLENN

JULY 30TH, 2018

by MICHAEL COLE

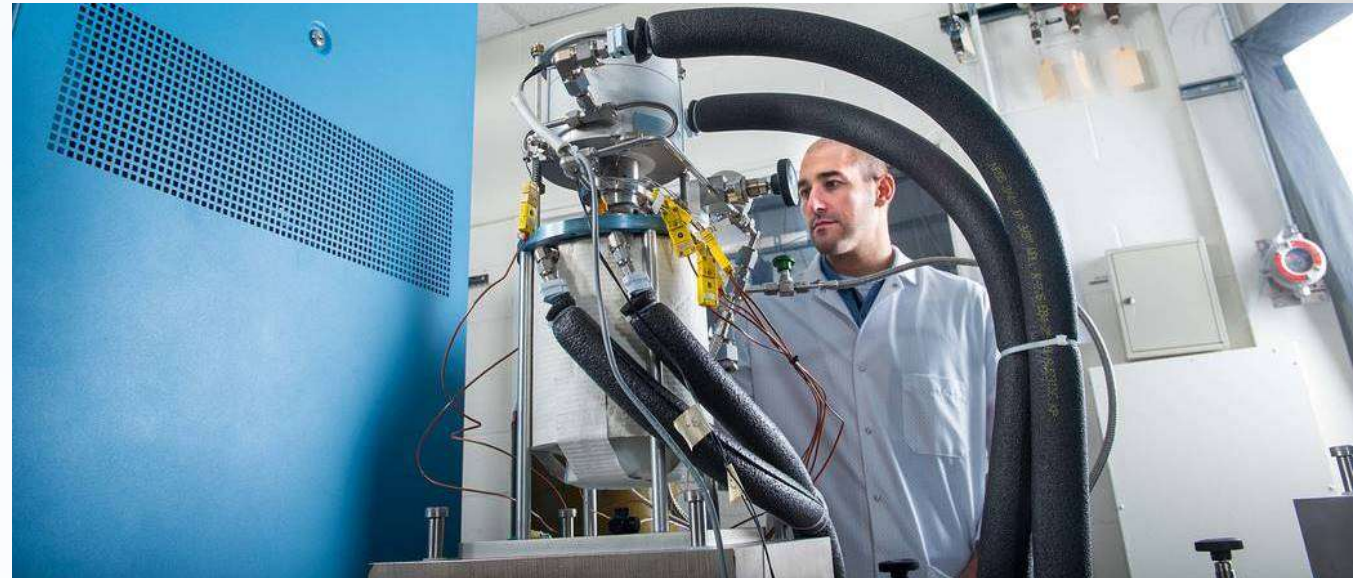

Courtesy of NASA, AeroSpace Frontiers, Vol. 20, Issue. 6, June 2018



# Leaders in Free-Piston Stirling Technology

Simple design and decades of expertise led to unparalleled reliability

- Welded, hermetically sealed enclosure - no helium refilling required
- Simple design - only 66 parts in the entire engine
- Proprietary flexure bearings technology enables frictionless linear movement with no contact or lubrication
- Designed for 80,000 maintenance-free operating hours
- Material fatigue life well beyond the required engine operating life
- Multiple levels of IP protection: patents, know-how, trade secrets, manufacturing tools

*“Wear mechanisms have been eliminated by non-contacting bearings and non-contacting seals.” [NASA](#)*

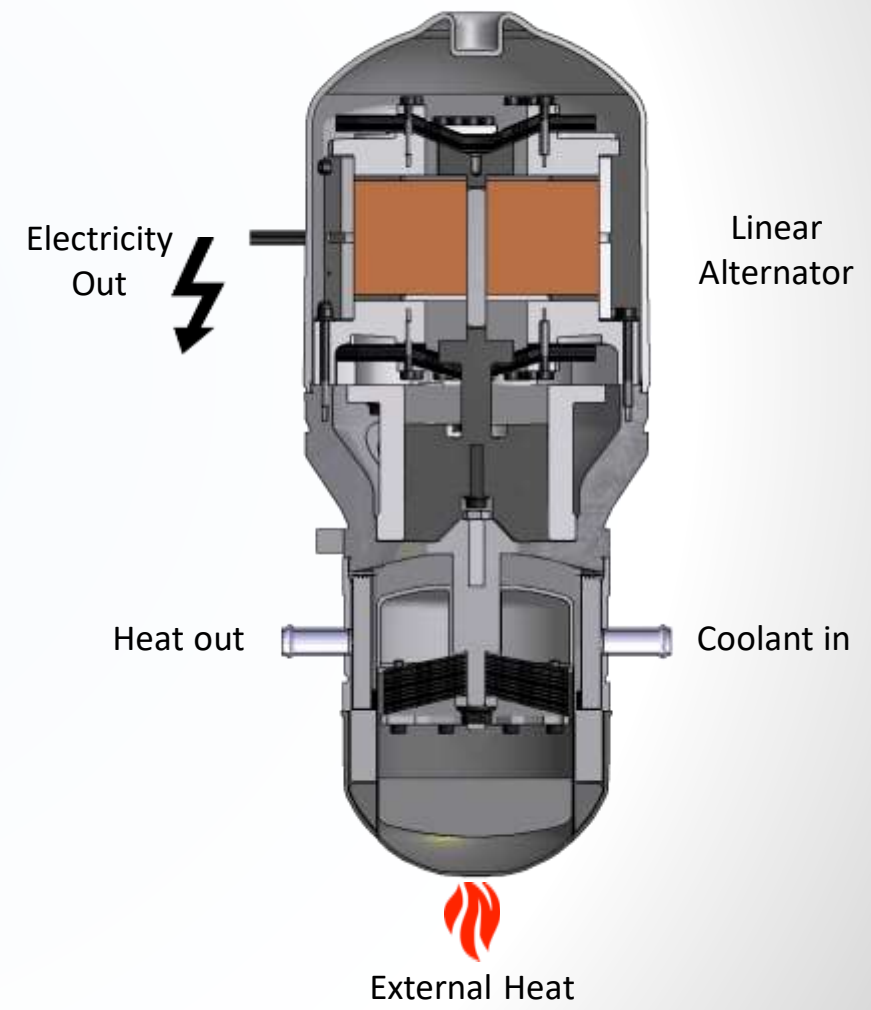



## Design Philosophy

Dispatchable and flexible power solution for a variety of power-needs marked by extreme reliability and low maintenance

*- all for competitive cost of ownership -*

## Core Technology

The PowerGen is based on the Qnergy Free Piston Stirling Engine (FPSE) with proven legacy in Military and Space applications.

- **Zero Maintenance Generator**
- ◇ Friction-Free ◇ No Rotating Parts ◇ Sealed
- **Highly Reliable in Harsh Environments**
- **High Electrical Efficiency**
- **Multi-Fuel Capacity**



# Maintenance-free products

Multiple products support a variety of revenue streams



	PG 600	PG 1200	PG 1800	PG 5650
<b>Power</b>	Up to 600W	Up to 1,200W	Up to 1,800Watts	Up to 5,650W
<b>Fuel Type</b>	gaseous fuel (700 – 3200 BTU/SCF) <i>(Natural Gas, Ethane, Propane, Butane, etc..)</i>			
<b>Service</b>	Annual inspection			
<b>Feature set</b>	Optional specialized weather and output configurations			
<b>Noise level</b>	Less than 72db(A) at 1meter			
<b>Electrical Output</b>	120Vac / 240 Vac (standard) <i>AC and DC options available</i>			
<b>Remote monitoring</b>	Included			

# PowerGen – Select Applications



- Cathodic Protection
- Mainline Valve Control
- Instrumentation and metering for pipeline and well-pad
- Artificial-lift equipment
- Communication and SCADA systems
- Monitoring and site control
- Lighting, security and safety equipment
- Renewable power backup and buffer
- Methane Reduction Applications (Air Compressors)

# Peace of mind: reliability and remote monitoring

Remote monitoring, connectivity and communication anytime, anywhere



“ The ability to troubleshoot a device in an hour, remotely is absolutely critical. Kudos to your team!”

*Cathodic Protection Manager in a leading Oil & Gas company*

Stable output

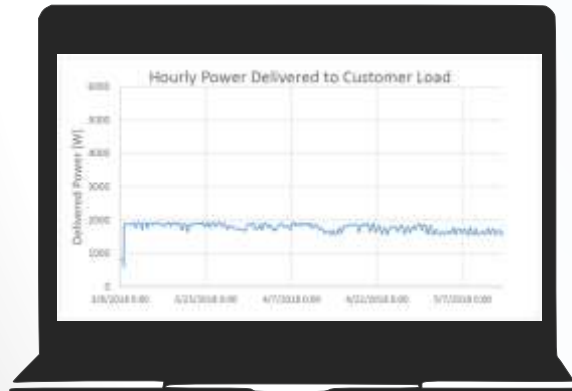

Organization	System S/N	State	Run Time [hrs]	AC Power [kW]	Product Type	Last Seen
Farwest Corrosion Control Co	PG124	ENABLED	273	3.99	PowerGen	Just now
Highland West Energy	PG78	ENABLED	10020	1.84	PowerGen	Just now
BC12/BC62 Metering	19	ENABLED	10020	1.44	PowerGen	Just now
	28	ENABLED		1.66	PowerGen	Just now
M.S. Jacobs	PG126	ENABLED	370	1.66	PowerGen	Just now
M.S. Jacobs	PG116	ENABLED	2394	5.68	PowerGen	Just now
M.S. Jacobs	PG112	ENABLED	479	1.53	PowerGen	Just now



# PowerGen – Key Component Overview



TECNOLOGÍA TOTAL  
www.tecnologiatotal.net

## GENERATOR

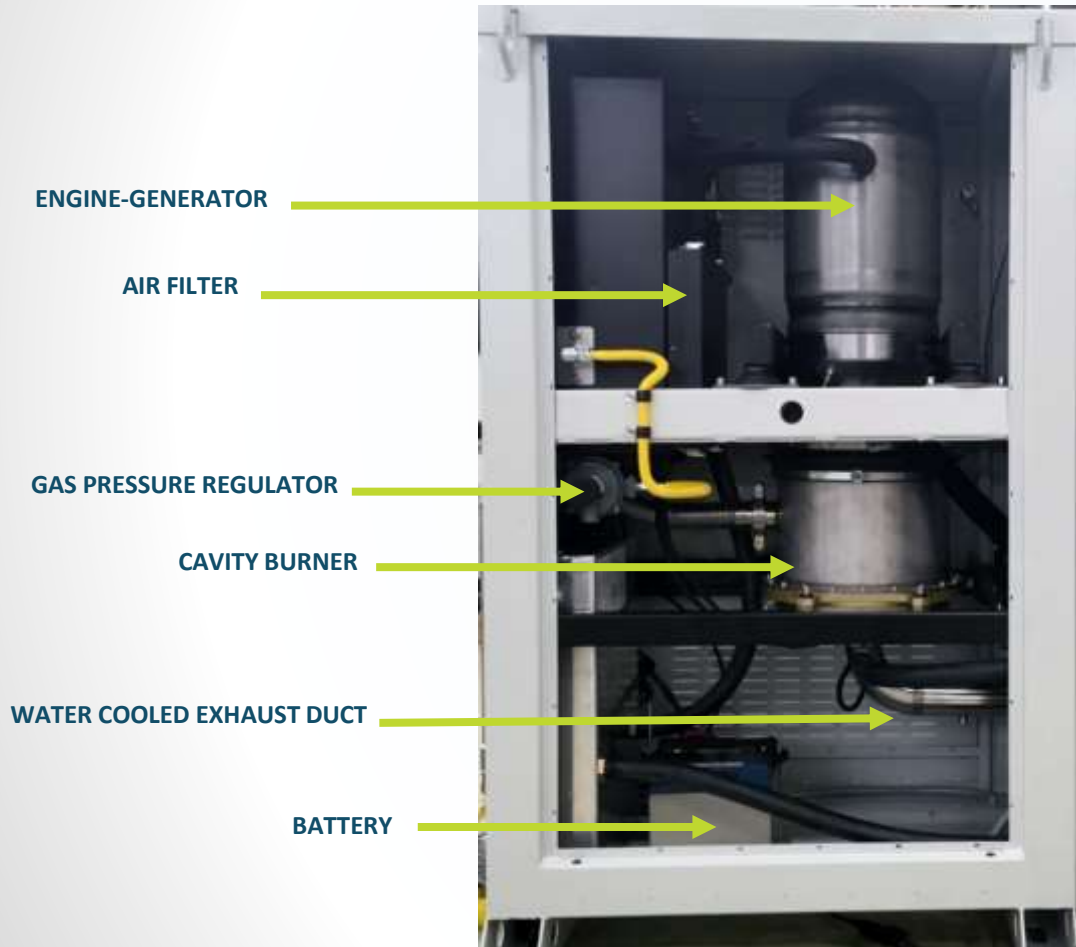

## Heat Rejection Unit

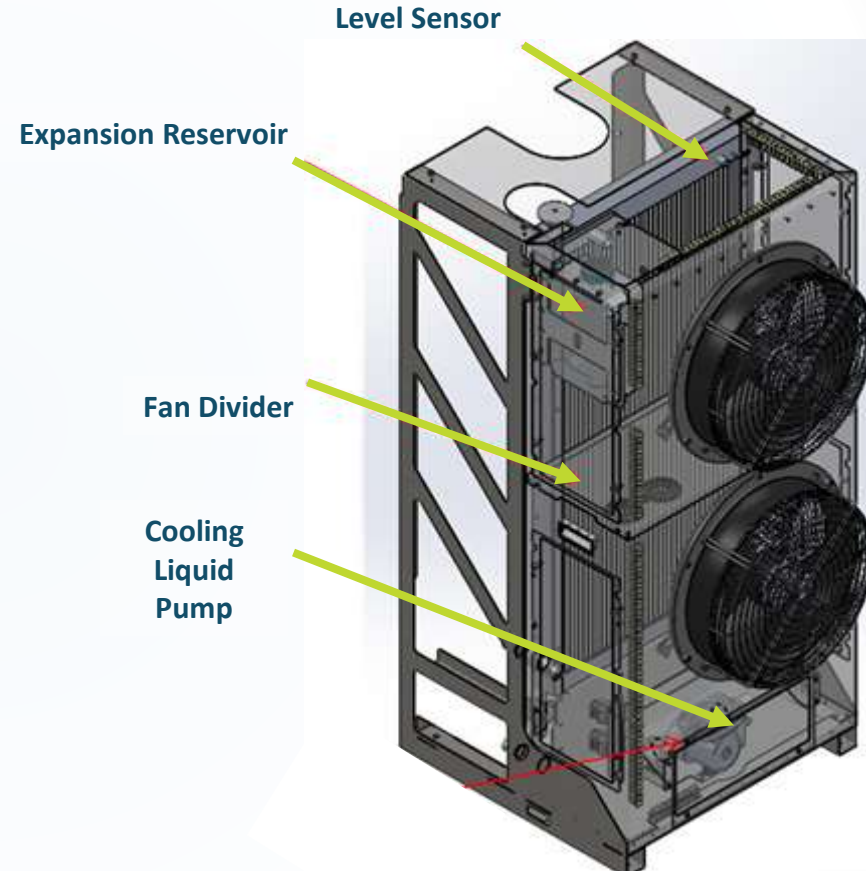

# Special Add-On Features:

## Heat Recovery Option



- ✓ Detachable hot-air heat recovery unit
- ✓ Liquid loop recovery as an additional option
- ✓ Heat Supply Ratio of x2.5 – 3.5 of electrical power
- ✓ Controllable supply temperatures

# Glycol Heating Loop (GHL) Module:

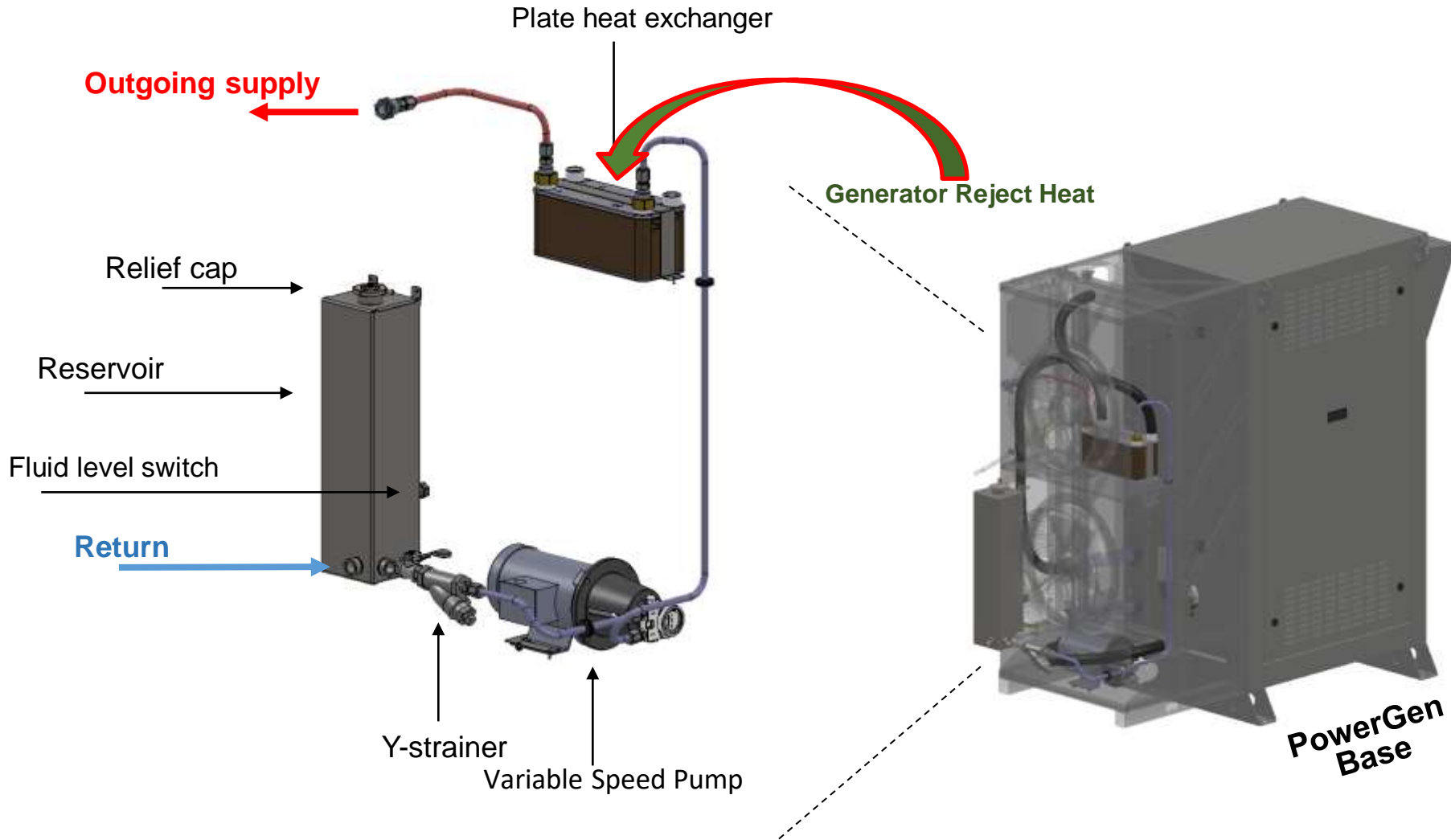



## GHT Module Specifications:

		<u>Units</u>
<b>Minimum Ambient Temperature</b>	- 40	°F
<b>Minimum Return Setpoint temperature</b>	77	°F
<b>Maximum Return Setpoint temperature</b>	135	°F
<b>Maximum 1/2" tube length</b>	1500	ft.
<b>Flow rate</b>	0.5-2.2	GPM
<b>Fluid reservoir - working volume</b>	1.5	gl.
<b>Fluid reservoir - expansion volume</b>	0.5	gl.
<b>Heat trace interface</b>	1/2" NPT Male	
<b>Coolant filter</b>	SST 100 mesh (150 micron)	
<b>Glycol content range</b>	Up to 50% vol. glycol content	
<b><u>Features</u></b>	<ul style="list-style-type: none"><li>• <b>Level switch for fluid low level warning.</b></li><li>• <b>No flow warning</b></li><li>• <b>Settable Return Setpoint temperatures</b></li><li>• <b>Monitors supply and return temperature</b></li><li>• <b>Controllable flow DC motored pump</b></li><li>• <b>Winter / Summer toggle switch</b></li></ul>	

# Heat Output Capacity:

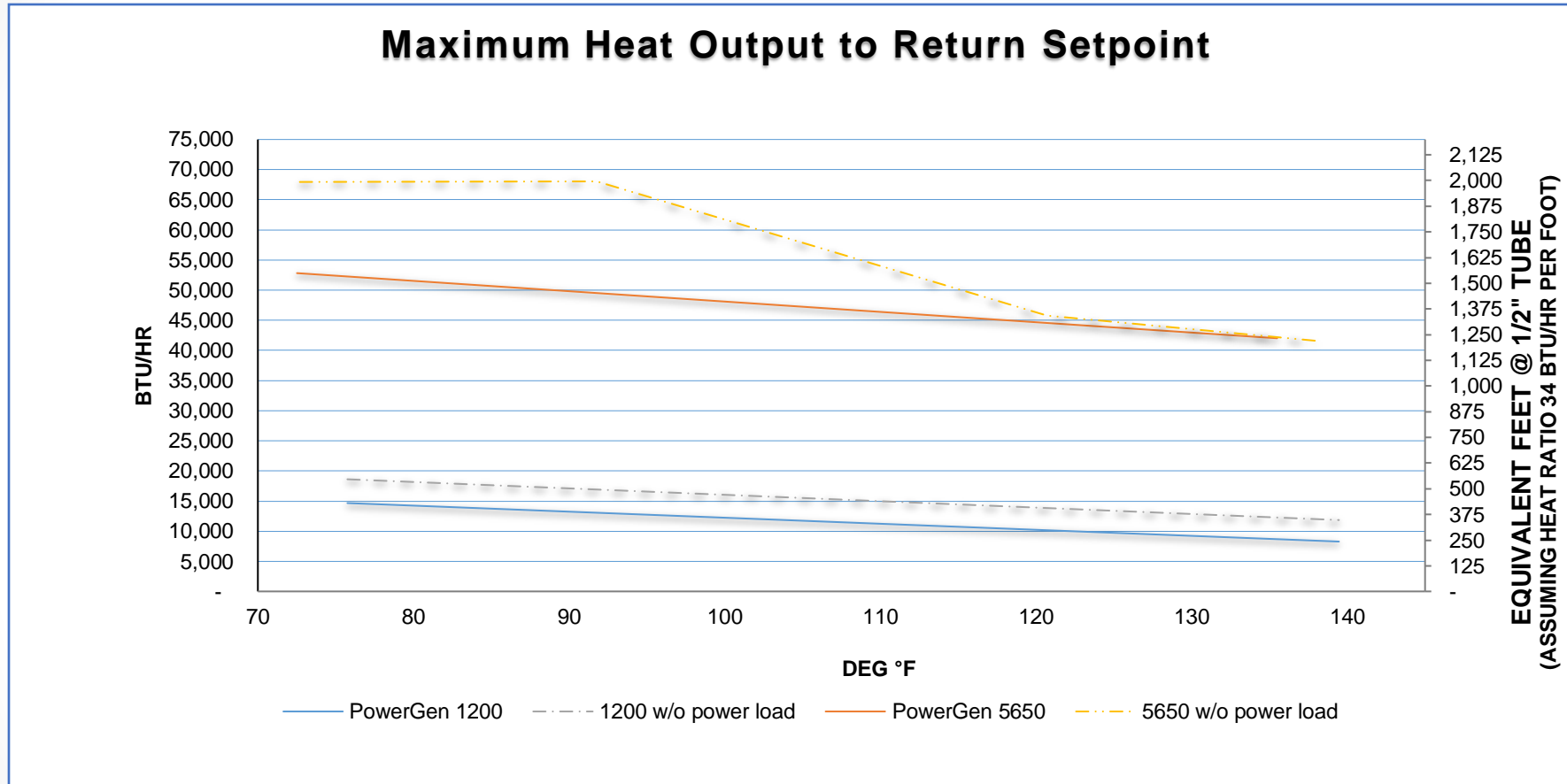

\* **Note:** The internal pump in all cases can circulate 50/50 glycol thru 1500' feet of ½" piping.

# Premixed / Lean Combustion:

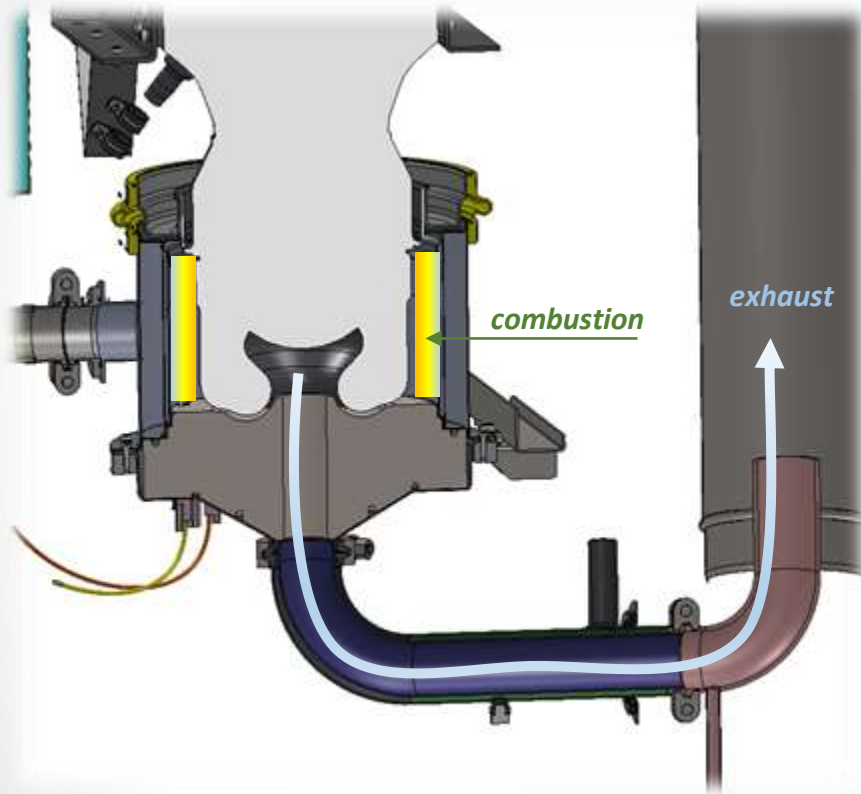

- Fully enclosed combustion chamber.
- Exhaust is diluted and exits at below  $< 200^{\circ}\text{F}$ .
- All surfaces are cooled.

Emissions	Value (English Units)	Value (SI Units)
NOx @ 5% O2	30.0 ppm	66.0 mg/kWh
CO @ 5% O2	9.0 ppm	12.0 mg/kWh
VOC	Content	Negligible, Lean Combustion*

# PowerGen Size Specification



TECNOLOGÍA TOTAL  
[www.tecnologiatotal.net](http://www.tecnologiatotal.net)

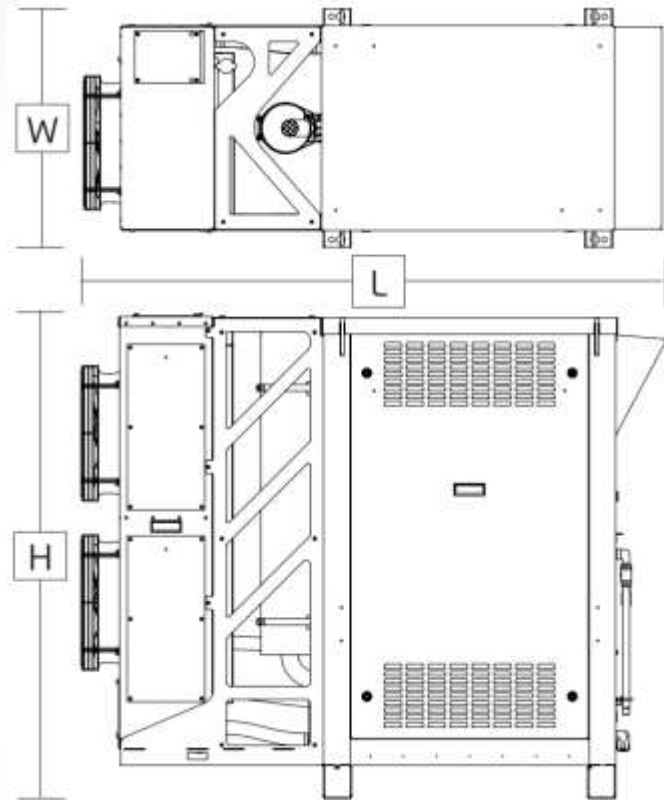

PowerGen Description	Measurement
PowerGen Length (L)	69.4 in
PowerGen Width (W)	28.1 in
PowerGen Height (H)	57.2 in
PowerGen Dry Weight	866 lbs
PowerGen Base Crate Length (L)	43.3 in
PowerGen Base Crate Width (W)	32.3 in
PowerGen Base Crate Height (H)	62.8 in
PowerGen Base Crate Weight	220 lbs

# Value Proposition

The loss of power is a loss of time; a loss of time is a loss of profits. Qnergy provides reliable power automatically, efficiently and quietly at a competitive price

## Qnergy

- \$65,000 USD for a 5,650 Watts system (*Exworks Ogden, UT*)
- 1-hr annual inspection
- Zero downtime



## Competition

- ~\$80,000 USD for a 1,100 Watts TEG system
- ~\$6,500 CAD annual service (Incl. replacement parts)
- ~ 10 days downtime per year





# Trusted by leading organizations

Select customers and partners (CAN)

Oil & Gas



The image displays a collection of logos for various organizations in the Oil & Gas industry. The logos are arranged in a grid-like fashion within a white box with a green header. The logos include: TOURMALINE (green and blue geometric shapes), MURPHY OIL CORPORATION (red star above blue text), CNOOC (red and blue circular logo), ENBRIDGE (yellow and blue stylized 'E'), ALLIANCE pipeline (red square with white interlocking circles), Shell (yellow and red scallop shell), NUVISTA ENERGY LTD (blue and white text), BIRCHCLIFF ENERGY (blue text), and KEYSERG (orange and black molecular structure logo).

# Trusted by leading organizations

Select customers and partners (USA)

## Oil and Gas



## Government and Industrial



## Future Markets



*“Visit every customer until we stop learning”*

# Case study: Protecting Natural Gas Pipelines

Enabling pipeline integrity and reducing leaks by reliable Cathodic Protection

## The situation

Cathodic protection is essential for maintaining pipeline integrity by protection against corrosion. Williams' remote sites that do not have a grid connection, need continuous reliable power to generate that impressed current

## The solution

The Qnergy PowerGen, using the Natural Gas available directly from the pipeline, provides continuous and maintenance-free power. The system is designed to operate autonomously providing power to existing ground beds given it's ability to sustain rapid switching for the Auto-Interrupt testing periods

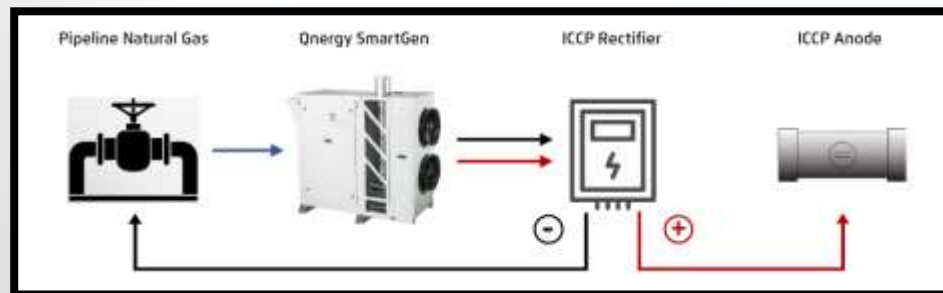

# Hybrid Solutions

- The PowerGen can provide complementary power to renewable energy inputs.
- Extremely fuel efficient as fuel is only consumed when no other renewable (Solar/wind/other) are present.
- Very reliable architecture with multiple parallel incoming energy streams.

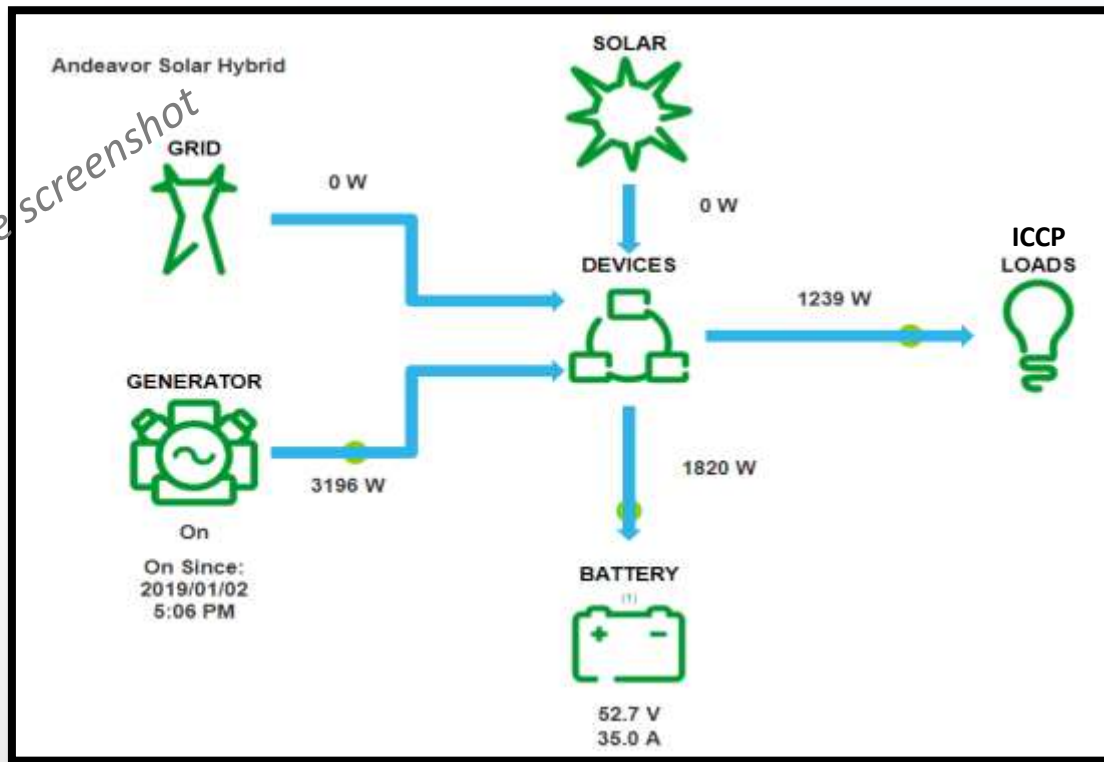

Qnergy

# Case study: Preventing ‘freeze off’

## Glycol Heat Trace for a well-pad ‘freeze off’ prevention

### The situation

Chesapeake gas production units suffer from “feed line” freezing. After many failed efforts to obtain an effective and reliable glycol heat trace system, Chesapeake engaged Qnergy to provide not only the electrical power to their well pad, but also the thermal heat to drive their glycol piping system

### The solution

Qnergy provided a remote power PowerGen 5650 which supplies up to 60,000 btu/hrs of heat as well as ample electrical power to drive all of the sites measurement and automation equipment

### The result

The PowerGen has successfully prevented freeze-off on the gas feed lines as well as provided seamless uninterrupted electrical power to the site thus significantly increasing the reliability of the well pad



# Case study: **Stable Power**

## Stable power for mission critical applications

### The situation

In order to maintain the reliable and safe operation of natural gas well pads, Southwestern Energy needed a power solution that they could count on for their mission critical instrumentation and SCADA, whether grid connected or not

### The solution

The PowerGen Stirling engine provides electric power in multiple configurations. In this instance, the PowerGen was configured to output 240VAC split phase power so as to mimic a standard utility grid connection allowing the company the flexibility it required

### The result

Southwestern is taking advantage of the PowerGen's outputs to provide reliable power to their 24VDC charging system as well as providing 120VAC outlets for additional on-site ancillary equipment

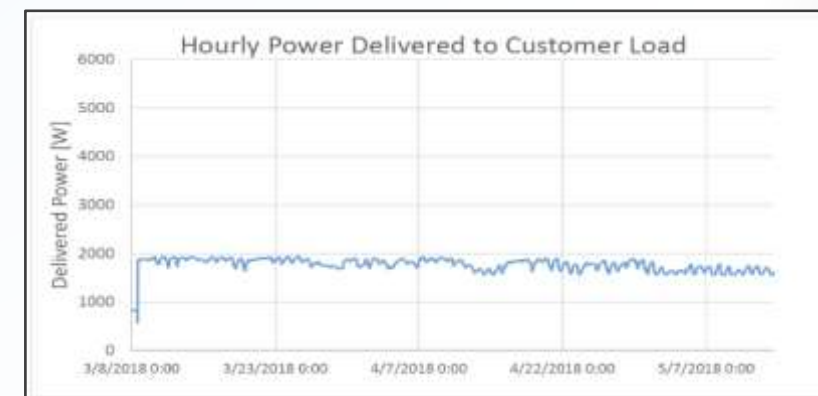

# Case study: Backup Power

## Backup power for remote facilities

### The situation

In order to increase the electrical reliability at a remote recreational facility in the Rocky-Mountains, Sinclair Oil employed the PowerGen as a maintenance-free ‘continuously operating’ backup generator.

### The solution

The PowerGen was configured to couple to the utility grid continuously offsetting the sites electrical bill and then, when electric utility power was lost, the PowerGen produced the needed power to drive the site’s basic set of emergency and security equipment.

### The result

The PowerGen provide the facility ‘always-on’, no maintenance backup power in event of grid failure.



*Daily:*  
130 kW-hr



# Case study: Backing up Solar Energy

## 100% uptime for a critical signaling station

### The situation

A critical railway signal site was serviced by solar PV and a wind turbine. The harnessed power was stored in a battery bank. Due to intermittency of both wind and solar the site suffered from frequent downtime. A diesel generator, that was brought on-site required repeated and costly maintenance, especially during winter.

### The solution

A PowerGen 5650 fueled by a 1000 gallon Propane tank to maintain the site's battery bank when wind and solar inputs are insufficient.

### The result

The signal site is now at 100% uptime with seamless response to load. Has been operating continuously for the year of trial in all weather conditions (regardless of renewable input) without any interruption or reduction in power availability



“ Not many are more pleased than myself with this system, except maybe the maintainer who does not have to visit this site every day in winter months due to power issues. This unit has kept our signal site up 100% over the last winter, which has been a big maintenance relief from years past. Thank you to all involved in this project.”

BNSF signal supervisor





# PowerGen Key Features

- **Price:** lower (\$/watt) than any comparable technology in this power range
- **Installation:** small footprint, easy installation, no landowner issues related to running power network, and avoid cutting trees to run power lines
- **Maintenance:** zero cost for lubricants, logistics and waste recycling
- **Flexible Fuel:** Operate on multiple gaseous fuels including well-site wet gas which reduces venting and flaring
- **Flexible Operation:** multiple start-stops or continuous operation, at same reliability
- **Control Functionality:** Dry contacts, relays and MODBUS for easy interfacing
- **Flexibility:** Modular and responsive power algorithms with multiple optional Vac and Vdc power
- **Remote Monitoring:** Web based connectivity and cloud based monitoring
- **Efficiency and Emissions:** Excellent efficiency while meeting stringent emission requirements.



Bringing a power pole to the end of the road...

# Thank you!



## QNERGY - CANADA

**Sergio Martinez**

Sales Manager - Canada

Email: [Sergio.Martinez@qnergy.com](mailto:Sergio.Martinez@qnergy.com)

Mobile: +1 403 462-8990

Website: [www.qnergy.com](http://www.qnergy.com)

Address: 300 W 12th St., Ogden, UT 84404



## TECNOLOGÍA TOTAL

**Ing. Juan Carlos Pachón**

CEO

Email: [jcpachon@tecnologiatotal.net](mailto:jcpachon@tecnologiatotal.net)

Mobile: +51 999 428-430

Website: [www.tecnologiatotal.net](http://www.tecnologiatotal.net)

Address: Av. Mariscal La Mar 638,  
Office 204, Miraflores, Lima-Perú

