



## Gradient Control Mat (GCM) Data Sheet

Personnel working near pipelines can be subject to electrical hazards such as lightning, AC fault current/voltage, and steady-state AC induction. "Ground mats" have typically been used at above ground pipeline structures where these hazards exist, but past designs do not provide adequate protection against lightning conditions.

Dairyland offers engineered Gradient Control Mats (GCM) to address lightning and AC fault current conditions, backed by analysis from experts in lightning protection and with a full review of the cathodic protection guidelines of this mat design. Step and touch potentials are now limited with the Dairyland grid-type mat, in a much lower cost design.

### Features and Characteristics

- Low cost design
- Fast construction using 4ft x 8ft sheets and exothermic welding
- Avoids handling and bending of zinc ribbon
- Low inductance design limits step and touch potentials due to lightning and AC faults
- Data available on design life and anode selection

### Sources of Unsafe Voltage

Electrical hazards can appear as a touch voltage or a step voltage. A touch voltage can exist when the point between a metallic object and the earth supports voltage to a hazardous level. This can be caused by an AC fault or lightning surge that raises the voltage of the metallic structure relative to earth. Piping near an AC power line corridor is subject to increased risk of faults and lightning strikes.

A step voltage hazard is where a large voltage gradient in the earth exists that appears between a person's feet. This is caused near an AC source such as a transmission or distribution line, or in the vicinity of lightning discharge. The resulting voltage gradient in the earth creates the step voltage hazard.

The Dairyland Gradient Control Mat addresses step and touch voltage issues by reducing the voltage gradient across the mat to very low levels, and by referencing the mat to the adjacent piping. The low inductance design of the GCM material provides extremely low voltage differences compared to single wire grounding systems, whether those other systems are oriented in a spiral or other arrangement, as any such arrangement is necessarily a high inductance design, resulting in large voltage differences. Dairyland technical documents outline the issues involved and recommend appropriate application guidance and best practices to users.

### GCM Recommended Locations for Use

The Gradient Control Mat should be applied where voltage differences can be present. This can include sites such as:

- Test stations in a power line corridor, to address step voltage, as well as touch voltage if test station connections can be contacted.
- Within 4 feet of above grade piping in stations. Matting can follow the path of the pipeline to afford step and touch voltage protection within facilities.
- Around valve controls at block valve sites, and at metering and regulator facilities near piping
- Approaches to fences and gates, to assure uniform voltage at contact points

### Advantages of Mat Decoupling

Dairyland also recommends decoupling gradient control mats to improve CP on the pipeline, and offers the affordable Solid-State Decoupler (SSD) line for use in conjunction with the Gradient Control Mat. For more information, visit [dairyland.com](http://dairyland.com)

Decoupling mats using the SSD allows for several distinct advantages including:

- The galvanic potential of the mat material has no effect upon pipeline CP
- Pipeline CP readings can be taken in the vicinity of the mat
- The life of the anodes used to protect the mat are significantly increased

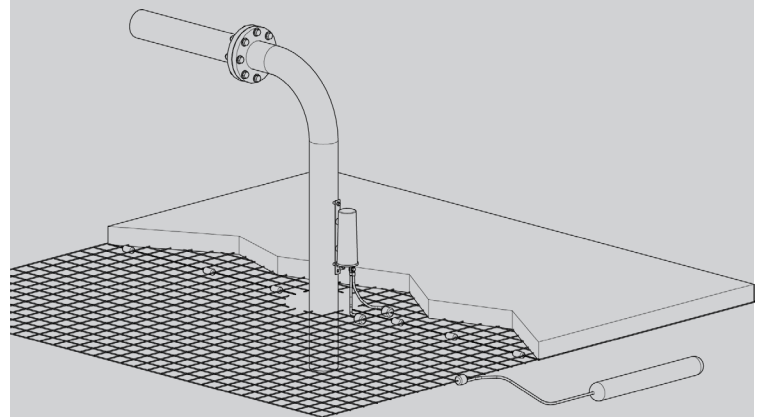

**GCM**  
**Gradient Control Mat**